

SIDEWINDER II

INSTALLATION INSTRUCTIONS

&

OPERATION MANUAL

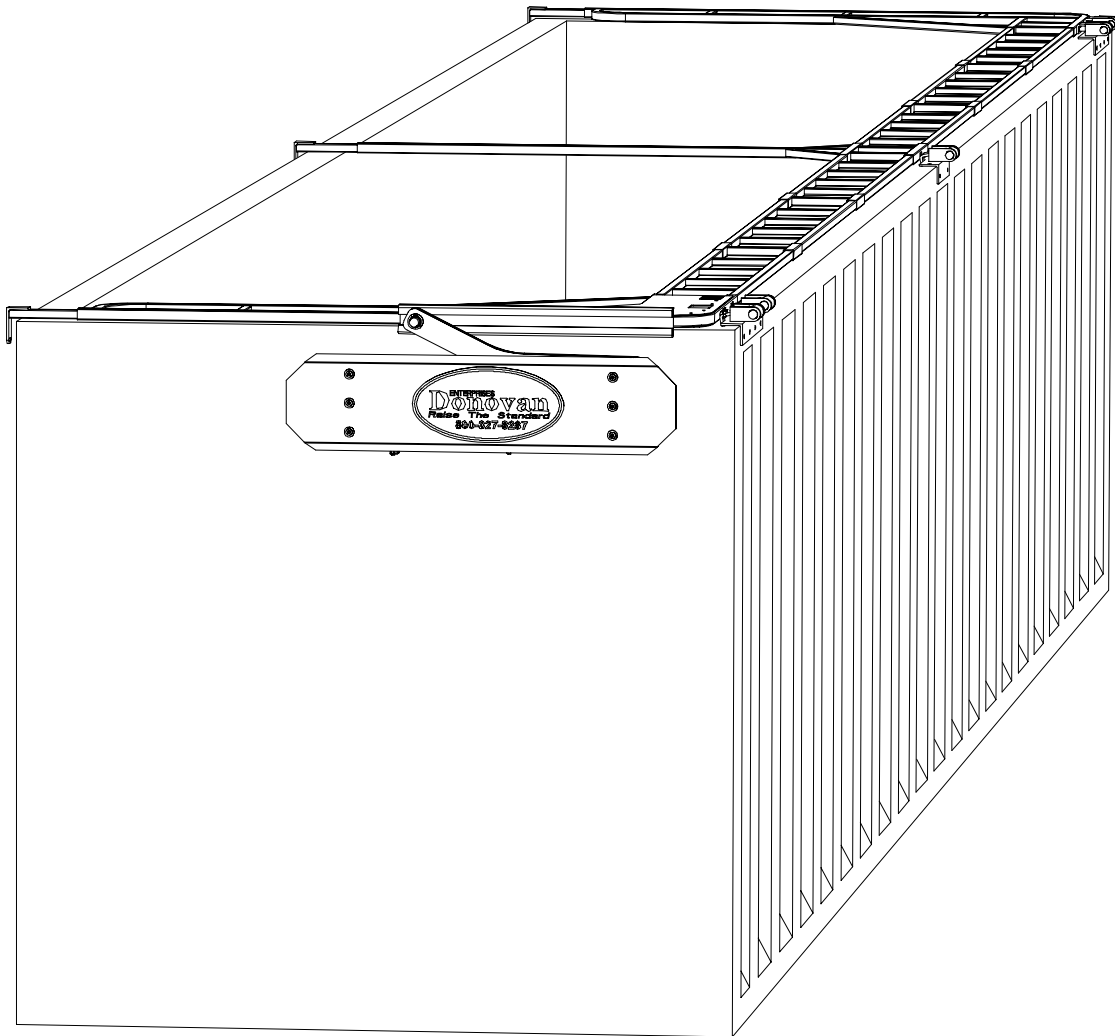

PATENT PENDING

AUGUST 2008

Donovan Enterprises
3353 SE Gran Park Way, Stuart FL 34997
800-327-8287
www.donovan-ent.com



PACKING LIST FOR SIDEWINDER II

P/N	QTY	BALLOON	DESCRIPTION
1059	1		SIDEWINDER II COMPLETE SYSTEM
1048	1	1	ACTUATOR ASSEMBLY, 134 lb (60.9Kg)
803	1	2	ACTUATOR ARM ASSEMBLY
805	1		ACTUATOR ARM WELDMENT
756	2		1 1/2 ID x 2" (3.81cm ID x 5.04cm) BUSHING
810	1		1 1/4" ID x 2 1/2" (3.17cm ID x 6.35cm) BUSHING
811	2		1 1/2 ID x .047 THK (3.81cm ID x .12cm THK) SHIM
8589	2		1 1/2 (3.81cm) EXT RETAINING RING
784	2	3	SHORT LINK ASSEMBLY
1665	1		1" ID x 1" (2.54cm ID x 2.54cm) BUSHING
2587	1		1 1/2 ID x 1" (3.81cm ID x 2.54cm) BUSHING
796	1	4	LONG LINK ASSEMBLY
1665	1		1" ID x 1" (2.54cm ID x 2.54cm) BUSHING
2587	1		1 1/2 ID x 1" (3.81cm ID x 2.54cm) BUSHING
1196	1	5	ROLLER ASSEMBLY (10" SHAFT W/ ROLLER)
779	2		UHMW ROLLER
1188	2		ROLLER SHAFT (10")
812	1	6	HYD. CYLINDER
1055	1	7	WIND DEFLECTOR
1056	1		LARGE WIND DEFLECTOR BRACKET
1057	1		SMALL WIND DEFLECTOR BRACKET
4311	2	8	FRONT + REAR HINGE ASSEMBLY
4313	1	9	CENTER HINGE ASSY
1051	1	10	FRONT LID WELDMENT, 91 lb (41 Kg)
2594	1	11	REAR LID WELDMENT, 41 lb (18.6 Kg)
2597	1	12	CENTER LID WELDMENT
2601	6	13	LADDER WELDMENT, 22 lb (10 Kg)
3313	1		BOX OF 4 "H" CONNECTORS
2603	4	14	"H" CONNECTOR
3317	2	15	LID EXTENSION WITH CABLE
2609	1	16	LID EXTENSION WITH OUT CABLE
2631	2		3/16 X 15' (.476cm x 457cm) CABLE WITH TURN BUCKLE
2631	2		3/16 X 15' (.476cm x 457cm) CABLE WITH TURN BUCKLE
2734			HYDRAULIC PUMP ASSY. 12V @ 2100psi (144.8 bar)
2532			HYDRAULIC PUMP 12V @ 2100psi (144.8 bar)
2779			HYDRAULIC PUMP ASSY. 24V @ 2100psi (144.8 bar)
2767			HYDRAULIC PUMP 24V @ 2100psi (144.8 bar)
1437			PUMP MOUNT BRACKET
1906	1		TARP, STANDARD SIDEWINDER (POLYESTER ORANGE KNIT 9 1/2' x 53'
3742			SOLENOID COVER

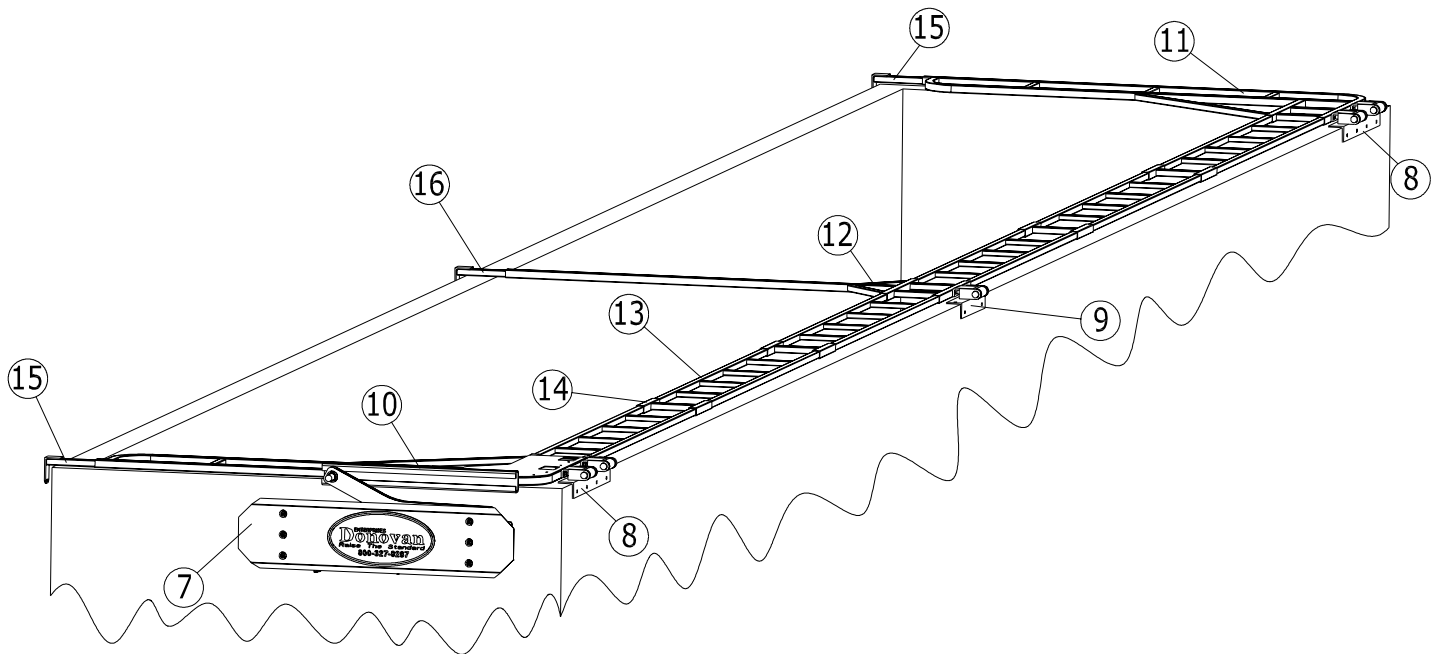
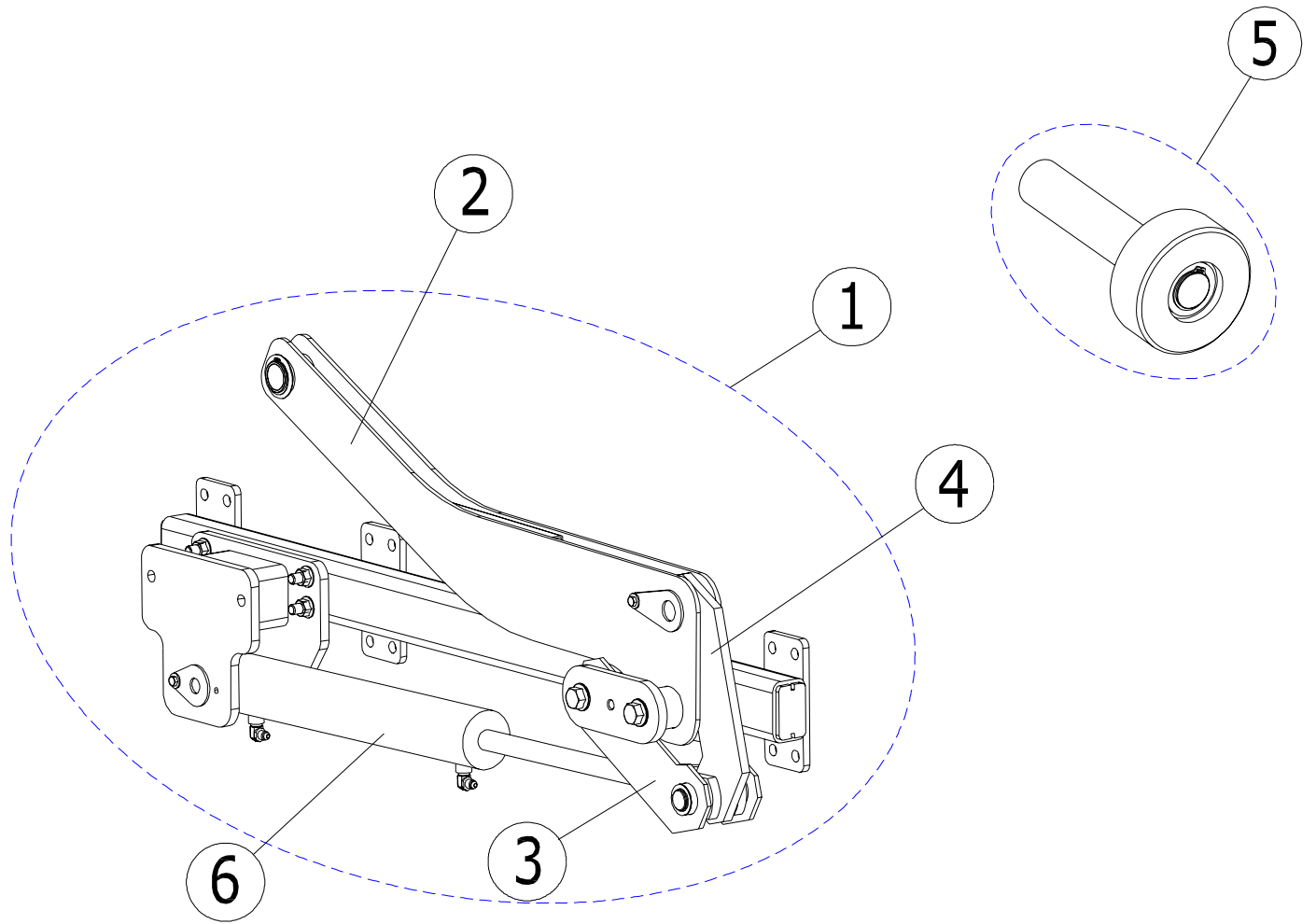

HARDWARE LIST FOR SIDEWINDER II

P/N	QTY	DESCRIPTION
2622	10	1/2-13 x 3, GR 5 FOR HINGE TO LID
2877	15	1/2-13 LOCK NUT FOR HINGE TO LID
2878	50	1/2 WASHERS FOR HINGE TO LID
916	3	1/2-13 x 2 LONG BOTTON HEAD, STAINLESS
1341	3	1/2-13 x 3 LONG BOTTON HEAD, STAINLESS
917	6	1/2 WASHER STAINLESS
2874	6	3/8-16 LOCK NUT
2875	10	3/8 WASHER
2464	4	3/8-16 X 1 1/2 LONG GR 5 BOLT
2630	6	3/16 CABLE NUT
2827	150	8" BLACK WIRE TIES, 120lbs
3299	20	1/4 x 3/4 SELF DRILLING SCREWS
2689	15	3/4" STEEL LOOP STRAP
3858	1	LOCTITE 262, .5ml
1144	10'	SPIRAL WRAP PE
SPLICE TAPE	6'	3M, SPLICING TAPE, 2"
4135	3	UHMW BUMPER STRIPS (INSTALLED ON LIDS WHERE THEY TOUCH THE TRAILER)
3325	2	1 1/2" ROUND RUBBER BUMPER (HYDRAULIC PUMP)

WET KIT OPTION

P/N	QTY	DESCRIPTION
3972		WET KIT COMPONENTS

NOTE: FOR COMPLETE LIST OF HARDWARE AND INSTALLATION SEE PAGE 19-21.

THESE INSTRUCTIONS SHOW THE SYSTEM BEING INSTALLED ON THE DRIVER SIDE OF THE TRAILER. FOLLOW THE SAME INSTRUCTIONS AND DIMENSIONS IF INSTALLATION IS TO BE ON THE PASSENGER SIDE.

1. PLACE TEMPLATE ON FRONT OF TRAILER AS SHOWN BELOW, AND MARK THE HOLE LOCATION ON THE FRONT OF THE TRAILER AT EACH CROSS (IF THE TRAILER IS STEEL, THE UNIT COULD BE WELDED INTO PLACE. NOTE: IF WELDING TO TRAILER USE EXTREME CAUTION TO AVOID GETTING WELD SPLATTER ON THE CHROME CYLINDER ROD. THIS WILL CAUSE PERMANENT DAMAGE TO THE CYLINDER AND VOID THE SYSTEMS WARRANTY).

NOTE: IF TRAILER HAS A ROUND OR 45 deg FRONT CORNER YOU MUST SUPPORT THE FULL ACTUATOR UNIT. BRACE AND GUSSET BEHIND THE UNIT AS NECESSARY.

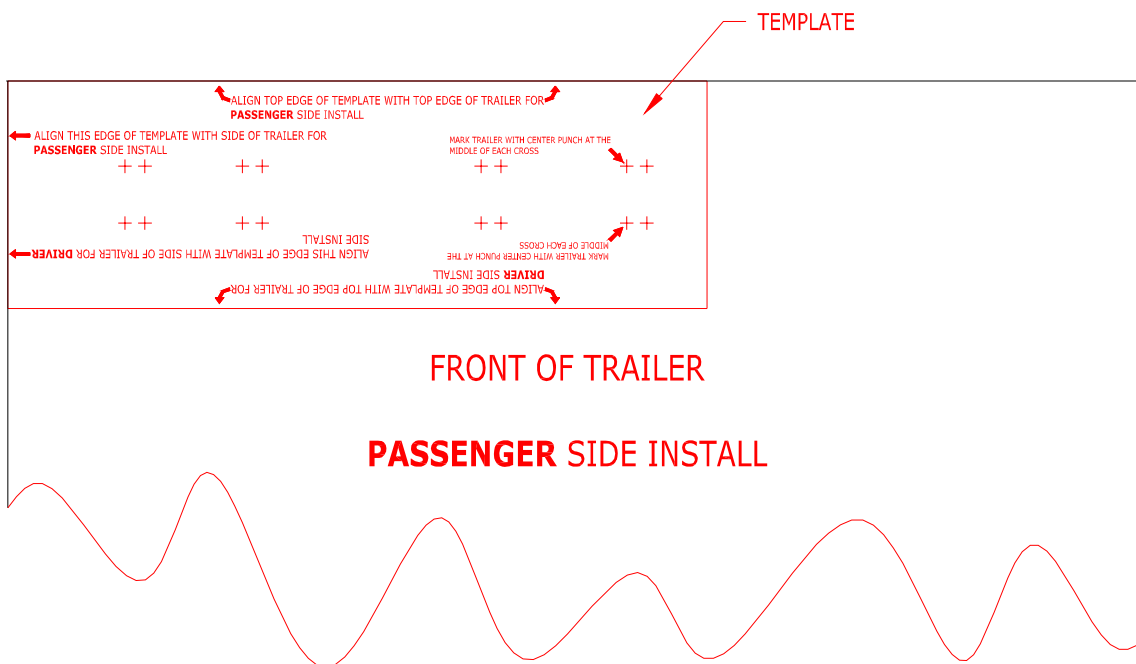
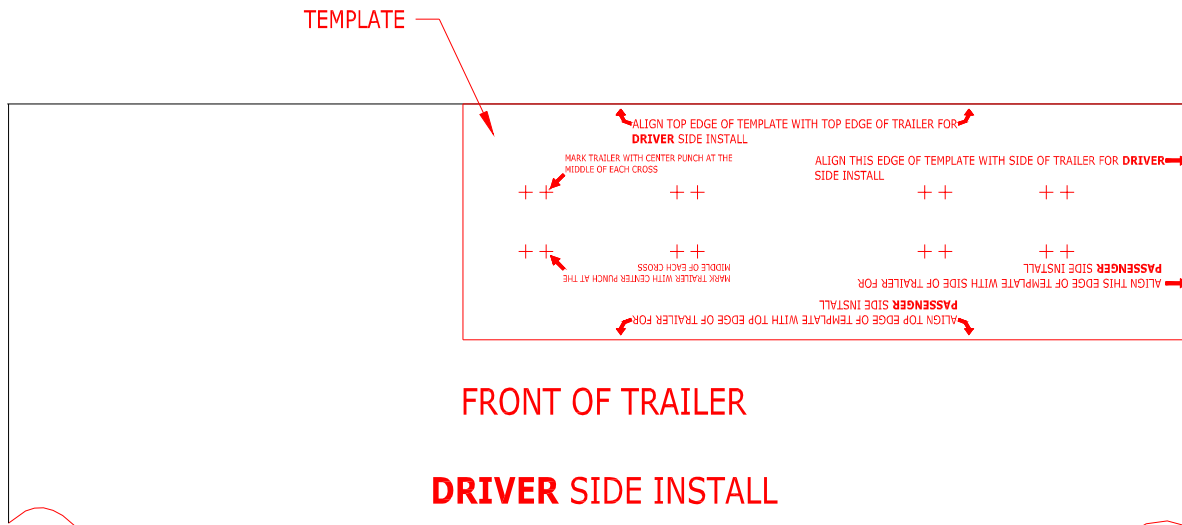

2. DRILL THE MARKED HOLE LOCATIONS TO ACCEPT 1/2" (1.3 cm) GRADE 5 (CLASS 8.8) OR BETTER BOLT (NOT SUPPLIED).
3. POSITION UNIT INTO POSITION, AND SECURE USING 1/2" (1.3 cm) BOLTS MENTIONED IN STEP #2. THE ACTUATOR UNIT WEIGHS 134 lb (61 Kg). USE A OVER HEAD LIFTING DEVICE, AND SLING TO LIFT INTO MOUNTING LOCATION. PLACE SLING AROUND EN TIRE UNIT AT LOCATION MARKED "LIFTING POINT" IN DRAWING BELOW.

NOTE: IF FRONT WALL OF TRAILER IS THIN ALUMINUM OR STEEL, USE SUFFICIENT BACK-ING PLATES INSIDE OF TRAILER TO SUPPORT THE UNIT.

NOTE: FRONT WALL OF TRAILER MUST BE FLAT AND PERPENDICULAR TO THE TOP RAILS OF THE TRAILER FOR THE UNIT TO OPERATE PROPERLY. UNIT MUST BE SHIMMED AS NECESSARY TO ACHIEVE A "FLAT" FRONT WALL FOR PROPER OPERATION.

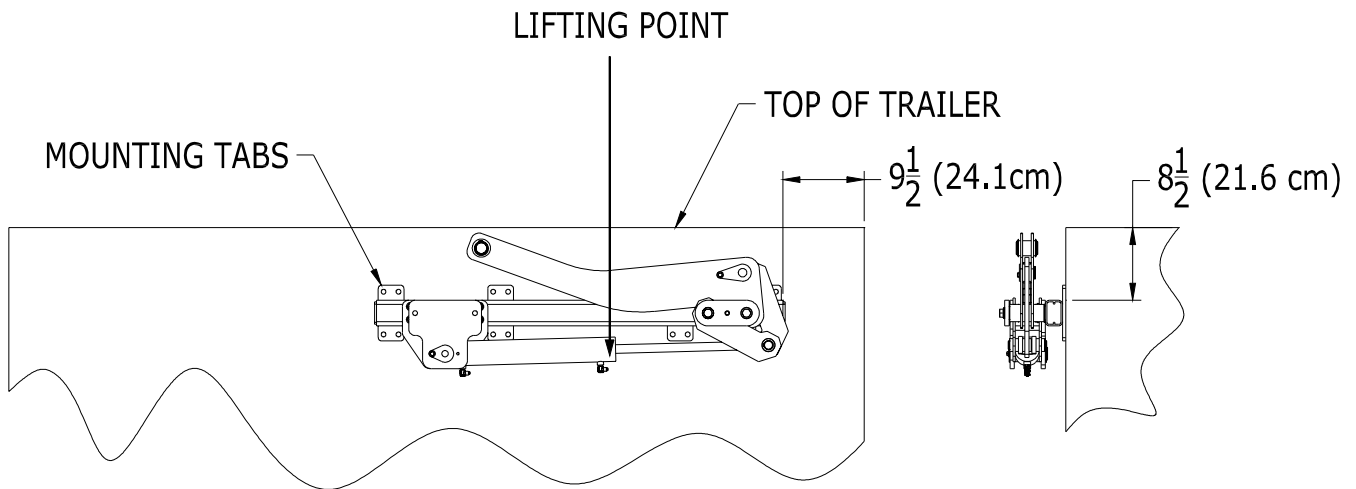

4. THE PLACEMENT OF THE HINGES IS SHOWN BELOW. IF THE TRAILER IS STEEL THE HINGES CAN BE WELDED INTO PLACE. ON AN ALUMINUM TRAILER USE THE HINGES AS A TEMPLATE, AND MARK THE HOLE LOCATIONS ON THE SIDE AND TOP OF TRAILER TOP RAIL. ON THE SIDE OF THE RAIL DRILL HOLES THROUGH TO THE INSIDE OF TRAILER TO ACCEPT 1/2" (1.3cm) GRADE 5 (CLASS 8.8) OR BETTER BOLTS (NOT SUPPLIED). ON THE TOP RAIL DRILL + TAP 1/2"-13 (M12) OR 1/2"-20 (M12) TO ACCEPT 1/2" (1.3 cm) GRADE 5 (CLASS 8.8) OR BETTER BOLTS (NOT SUPPLIED).

NOTE: TRAILERS WITH A CENTER SUPPORT ABOVE THE TOP RAIL MUST OFFSET THE CENTER HINGES TO EITHER SIDE OF THE SUPPORT.

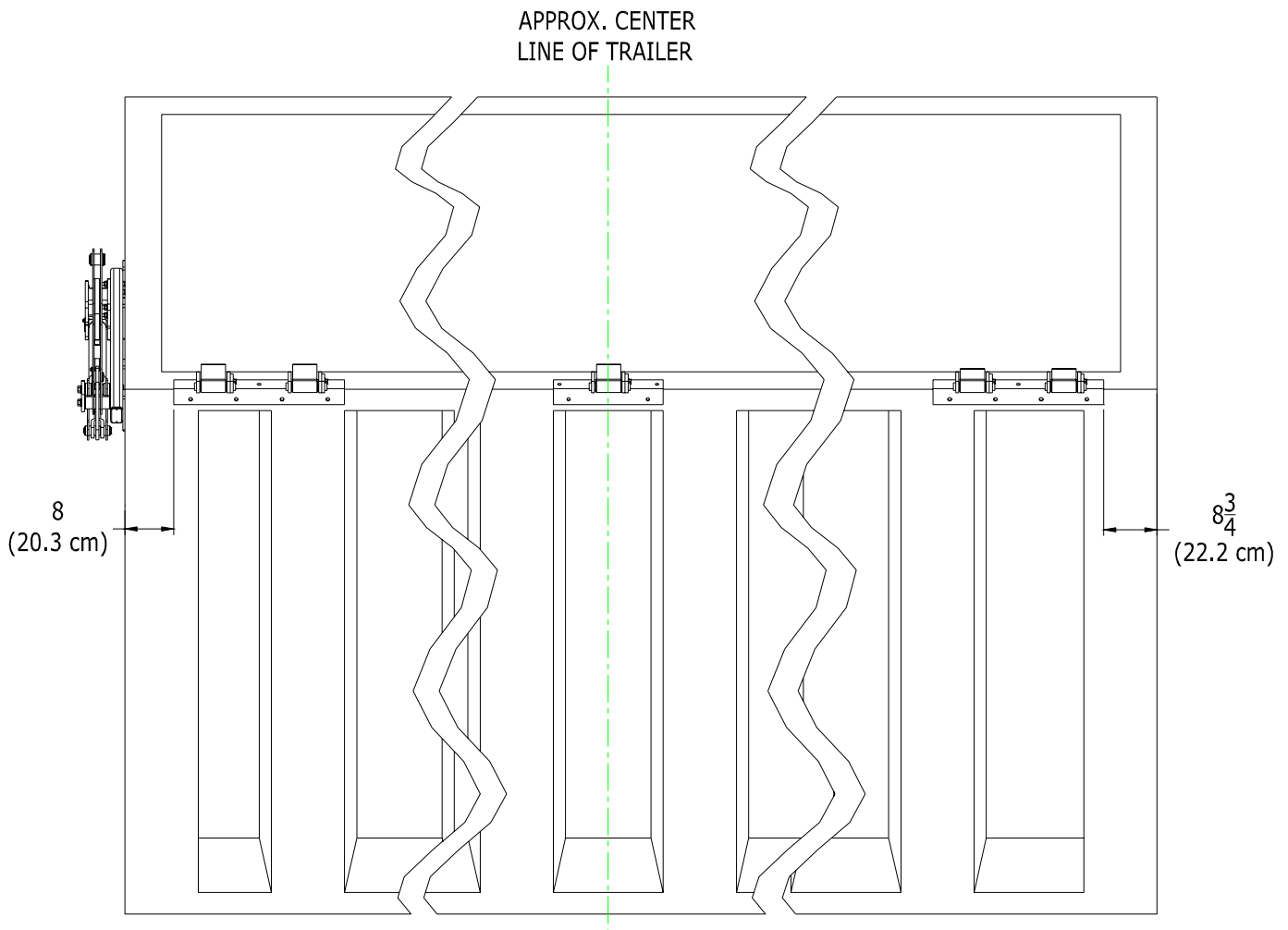

5. BELOW ARE THE LIDS WITH THE CABLE EXTENSIONS SLID INTO PLACE. MEASURE THE TRAILER OUTSIDE WIDTH AT THE FRONT, CENTER AND REAR OF THE TRAILER. USE THESE DIMENSIONS FOR THE APPROPRIATE LID AS SHOWN BELOW, AND WELD EXTENSION TO LID AT THAT WIDTH. NOTE: BOTH FRONT AND REAR LID EXTENSIONS HAVE CABLES ATTACHED TO THEM. THE CENTER EXTENSION DOES NOT.

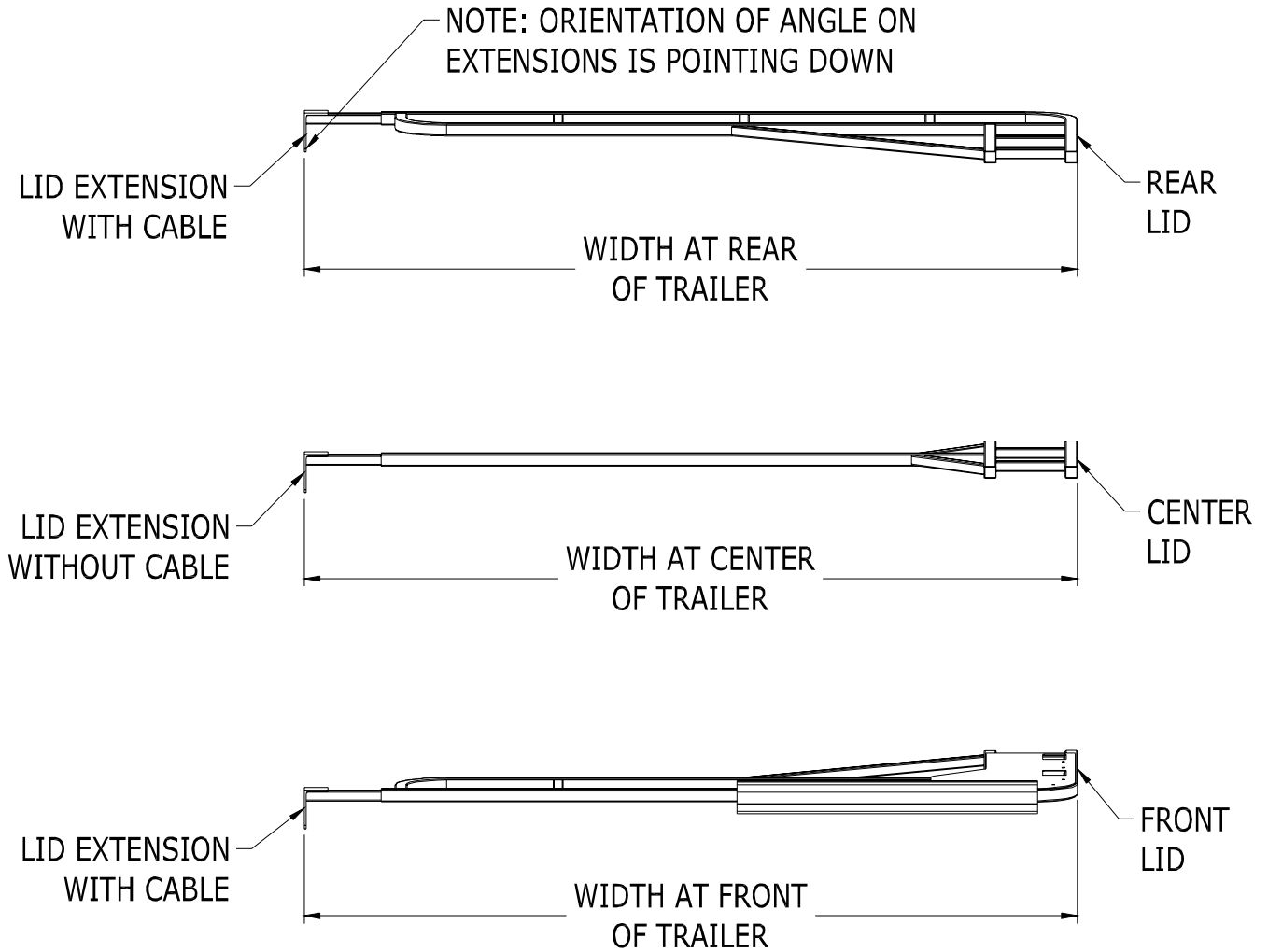

6. INSERT ROLLER AND SHAFT INTO ACTUATOR ARM AS SHOWN

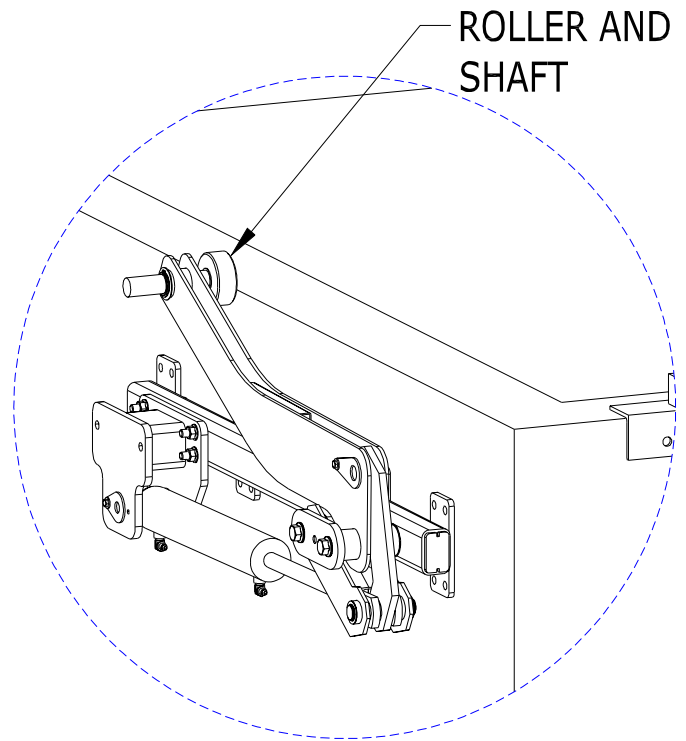

CAUTION!: AT THIS STAGE THE HYDRAULICS MUST BE INSTALLED, AND CYCLED TO ELIMINATE ANY AIR IN THE SYSTEM. FAILURE TO DO THIS COULD RESULT IN PERSONAL INJURY, AND/OR DAMAGE TO THE SYSTEM AT A LATER STAGE.

7. HOLD THE PUMP MOUNT BRACKET IN PLACE AS A TEMPLATE ON THE FRONT OF THE TRAILER JUST BELOW THE ACTUATOR UNIT (APPROX 12", (30.5cm)). MARK THE LOCATION OF THE (4) HOLES, AND DRILL THROUGH TO EXCEPT 3/8 x 1 1/2 (.88cm x 3.81cm) LONG BOLTS PROVIDED. USE WASHERS AND 3/8 (.88cm) LOCK NUTS PROVIDED TO SECURE IN PLACE..



8. PLACE (4) RUBBER BUMPERS IN PLACE AS SHOWN AND SECURE PUMP BY USING 3/8-16 (.88cm) LOCK NUTS AND WASHERS.

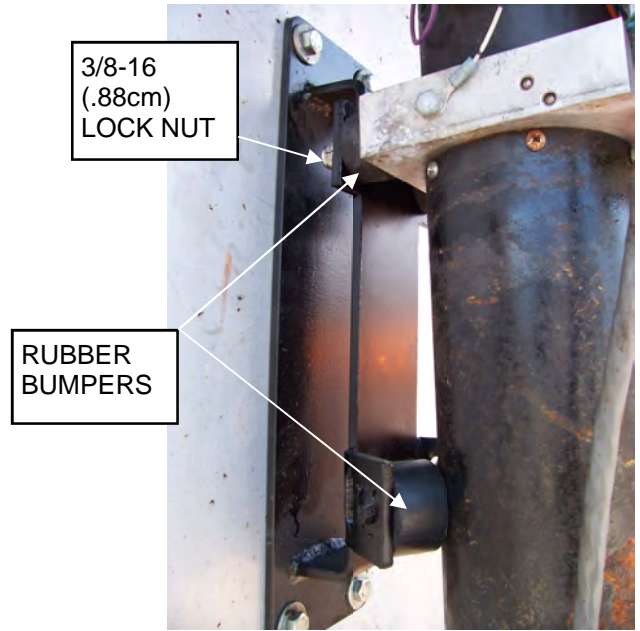

9. SECURE BOTTOM OF PUMP USING LARGE HOSE CLAMP AS SHOWN



10. CONNECT THE (2) HYDRAULIC HOSES TO THE PUMP AND CYLINDERS AS SHOWN. USE THE HOSE CLIPS AND SELF DRILLING SCREWS PROVIDED TO ORGANIZE AND SECURE THE HOSES.

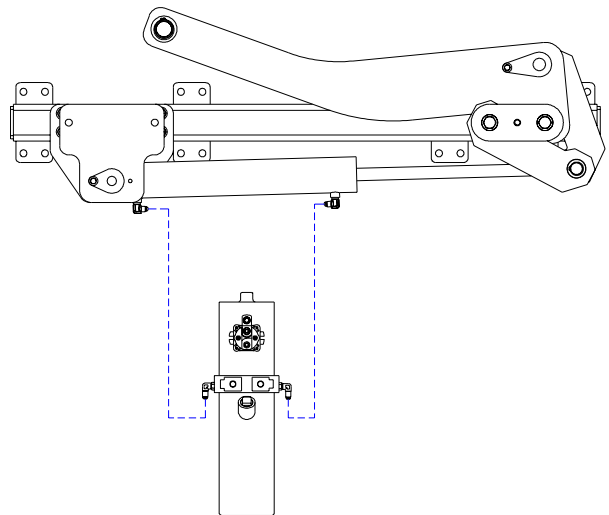

11. MOUNT CONTROL SWITCH AS SHOWN, WITH CABLE COMING FROM BOTTOM, USING (2) SELF DRILLING SCREWS PROVIDED.

IMPORTANT: INSTALL THE CONTROL SWITCH IN AN AREA WHERE THE OPERATOR CAN SAFELY OBSERVE AND OPERATE THE SYSTEM.

MOUNT THE QUICK DISCONNECT POWER CABLE NEAR THE CONTROL SWITCH SO THE OPERATOR HAS EASY ACCESS.

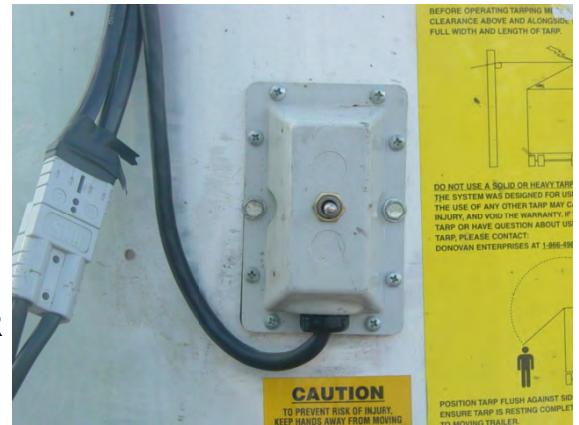

USE THE HOSE CLIPS AND SELF DRILLING SCREWS PROVIDED TO ORGANIZE AND SECURE THE CABLES TO FRONT OF TRUCK.

INSTALL ALL SAFETY STICKERS NEXT TO THE CONTROL SWITCH. SEE PAGE 17 FOR STICKER DESCRIPTION.

REMOVE RED CAP FROM THE FILLER NECK ON PUMP, AND FILL PUMP WITH APPROXIMATELY (3) QUARTS (2.83 L) OF DEXTRON AUTOMATIC TRANSMISSION FLUID. REPLACE RED CAP WITH BLACK BREATHER CAP.

NOTE: UNDER NORMAL OPERATING CONDITIONS THE FLUID IN THE HYDRAULIC PUMP WILL LAST THE LIFE OF THE PUMP. IN EXTREME DIRTY OR WET CONDITIONS, CHECK THE FLUID EVERY FOUR TO SIX MONTHS, AND CHANGE IF NECESSARY.

12. CONNECT A 12V POWER SUPPLY TO THE QUICK DISCONNECT POWER CABLE, AND CYCLE THE CYLINDER (10) TIMES TO REMOVE ANY AIR IN THE SYSTEM. **FAILURE TO DO THIS COULD RESULT IN PERSONAL INJURY, AND/OR DAMAGE TO THE SYSTEM AT A LATER STAGE.**

13. SLIDE FRONT LID ROLLER TRACK OVER THE ROLLER, AND ATTACH THE LID TO THE HINGES USING 1/2" x 3" (1.3cm x 7.6cm) BOLTS, LOCK NUTS AND WASHERS PROVIDED. THE FRONT LID AND HINGES (SHOWN) USE (4) BOLTS, THE REAR ALSO USE (4) BOLTS, AND THE CENTER LID USES (2) BOLTS.

NOTE: THE FRONT LID WEIGHS 91 lb (41 Kg). USE A OVER HEAD LIFTING DEVICE, AND SLING TO LIFT INTO MOUNTING LOCATION. PLACE SLING AROUND TUBE AT LOCATION MARKED "LIFTING POINT" IN DRAWING BELOW.

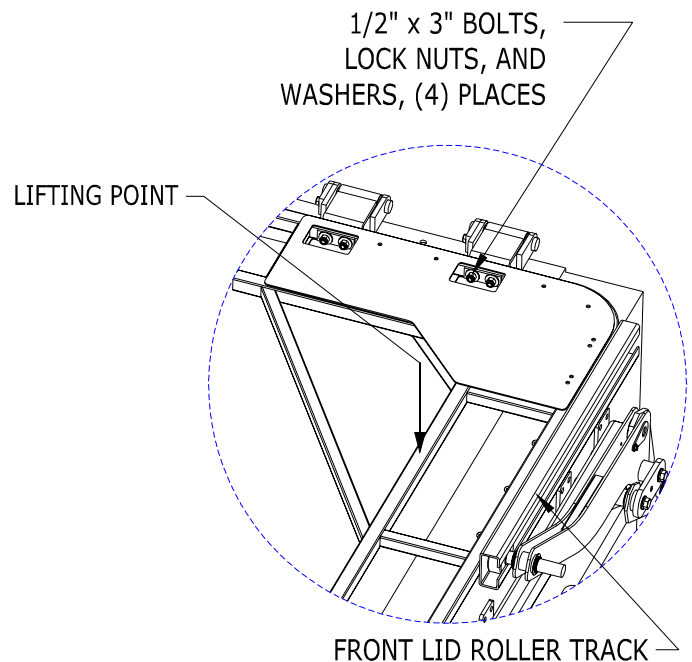

14. MEASURE THE DISTANCE BETWEEN THE LIDS IN THE (2) PLACES SHOWN.

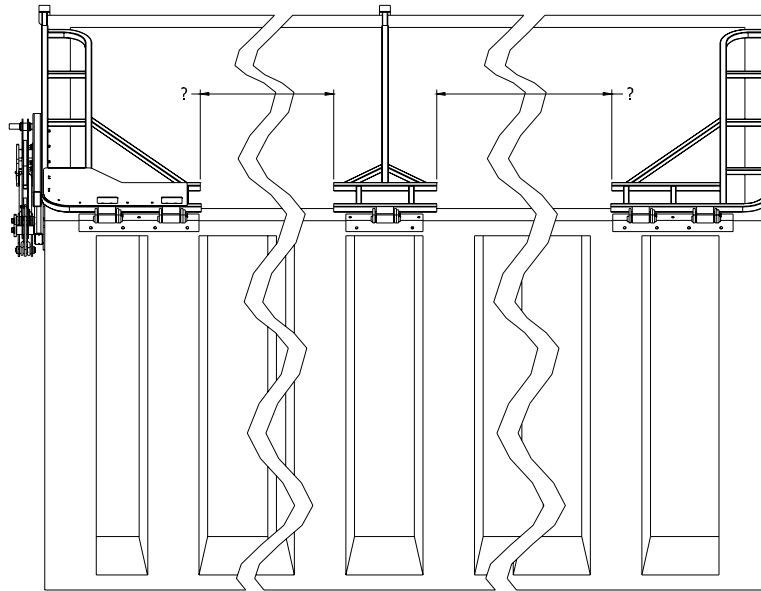

15. ADD 8" (20.3 cm) TO EACH OF THE (2) MEASUREMENTS TAKEN IN STEP #10. THIS WILL BE THE LENGTH OF THE LADDER SECTIONS BETWEEN THE LIDS. WELD THE "H" CONNECTORS AND LADDERS ON THE GROUND AS SHOW BELOW. THE LADDER SECTION MAY NEED TO BE CUT, AND/OR EXTRA "H" CONNECTORS AND LADDERS (SUPPLIED) MAY BE USED TO OBTAIN THE DESIRED LENGTH.

NOTE: WHEN LADDER SECTIONS ARE WELDED TOGETHER THEY CAN WEIGH AS MUCH AS 70 lb (31.8 Kg). USE AN OVER HEAD LIFTING DEVICE AND SLING TO LIFT INTO PLACE. LOCATE SLING AT THE CENTER OF THE WELDED LADDER SECTIONS TO EVENLY DISTRIBUTE THE WEIGHT.

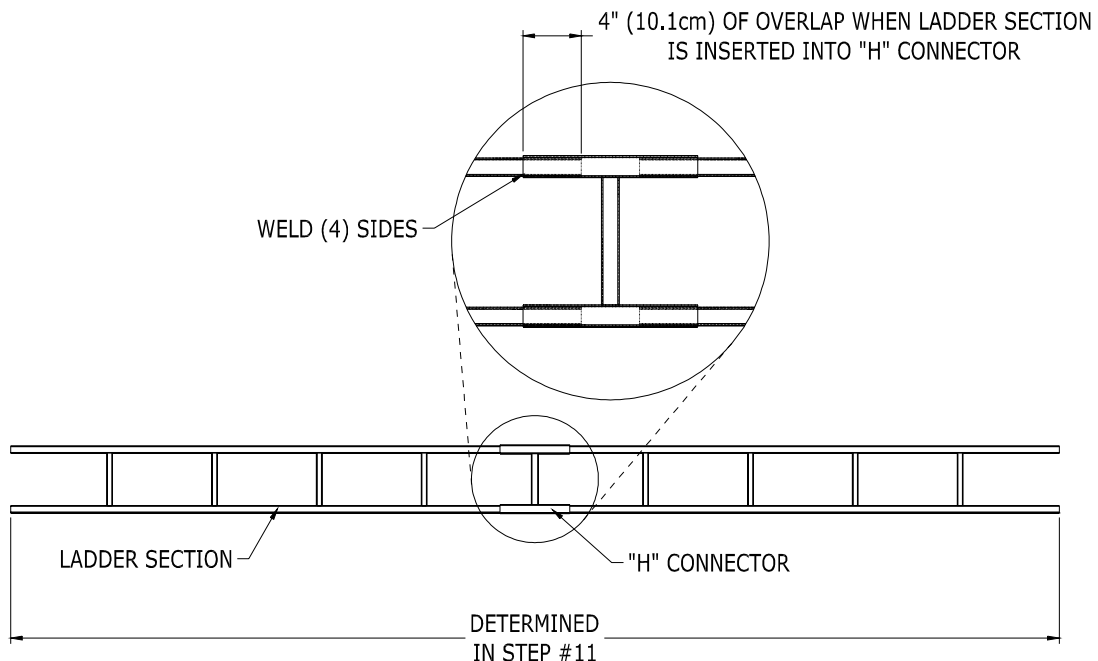

16. RAISE THE APPROPRIATE LADDER SECTIONS INTO PLACE, AND SLIDE 4" (10.1cm) OF THE LADDER INTO EACH LID, AND WELD AROUND ALL FOUR SIDES OF EACH LADDER TO THE LID.

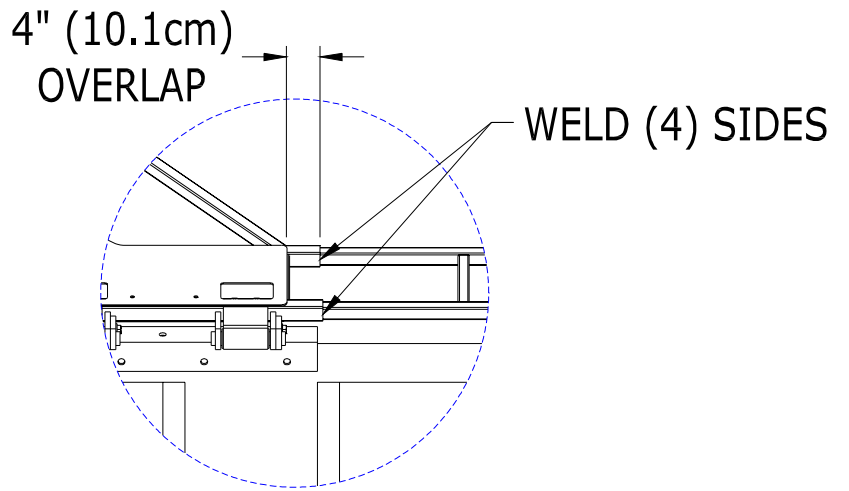

17. OPEN THE SYSTEM SO THE LID LAYS FLAT ON THE SIDE OF THE TRAILER TO INSTALL THE TARP CABLES AND TARP.
18. THE TARP CABLES ARE ALREADY ATTACHED TO THE FRONT AND REAR LID. EXTEND THE TURNBUCKLES SO THERE ARE FULLY EXTENDED ON THE TWO OTHER CABLES PROVIDED. ATTACH EACH TURNBUCKLE TO THE CENTER LID AS SHOWN BELOW. THERE WILL BE (4) CABLES, (1) ON THE FRONT LID, (2) ON THE CENTER LID, AND (1) ON THE REAR LID.



19. ATTACH THE CABLES TOGETHER FROM THE FRONT AND CENTER LID USING (2) CABLE NUTS PER SECTION AS SHOWN BELOW. DO THE SAME BETWEEN THE CENTER AND REAR LID. CABLE NUTS MUST BE TIGHT TO KEEP CABLES FROM SLOPPING.



NOTE: A NEW STYLE HD CABLE CLAMP MAY BE INCLUDED IN YOUR KIT. INSTALL THESE THE SAME AS ABOVE, AND TIGHTEN TO APPROX. 30 ft-lb (40.6 Nm)

20. TIGHTEN ALL THE TURNBUCKLES UNTIL THE CABLES ARE TAUGHT. NOTE: DO NOT OVER TIGHTEN THE TURNBUCKLES, THIS COULD CAUSE EXCESS STRESS ON THE LIDS AND HINGES. TIGHTEN THE JAM NUTS ON EACH TURNBUCKLE TO PREVENT LOOSENING (USE OF A LIQUID THREAD LOCKER IS RECOMMENDED ON THE JAM NUTS).

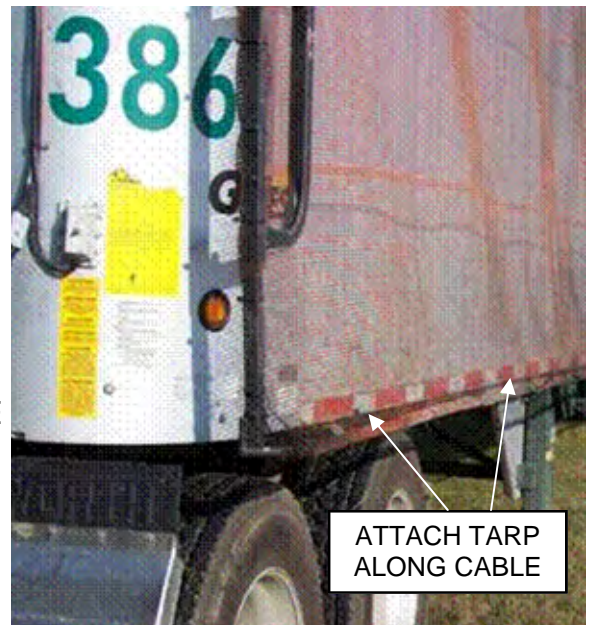

21. ATTACH THE TARP STARTING AT THE FRONT LID WORKING YOUR WAY TO THE BACK ON THE CABLE ONLY USING A ZIP-TIE AT EVERY 12" to 18" (30.5cm to 45.7cm) AS SHOWN. (TARP IS SHOWN INSTALLED)

22. TILT THE LID TO THE POSITION SHOWN AND ATTACH THE TARP, STARTING FROM THE FRONT, TO THE SYSTEMS LADDER SIDE USING ZIP TIES EVERY 12" to 18" (30.5cm to 45.7cm).



23. ATTACH THE TARP ALONG THE FRONT LID WITH ZIP TIES. USE THE HOLES AND CHAIN LINKS WHERE PROVIDED.

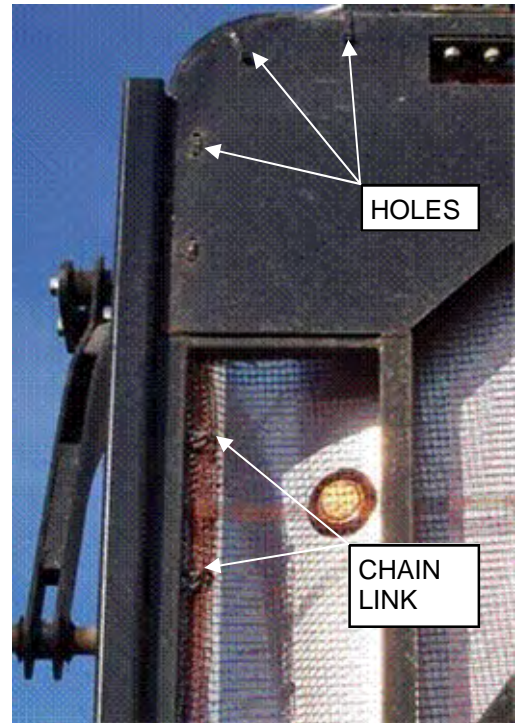

24. FOR TRAILERS THAT ARE SHORTER THAN THE TARP LENGTH, CUT THE TARP AT THE BACK OF THE TRAILER, BUT LEAVE APPROX. 6" to 8" (15.2cm to 20.3cm) EXTRA MATERIAL. FOLD OVER THE EXCESS MATERIAL, AND ZIP TIE ALONG REAR LID.

TIP: IF THERE IS A GAP BETWEEN THE REAR LID, AND THE TRAILER REAR DOOR, DO NOT CUT THE EXCESS TARP MATERIAL. ROLL THE EXCESS TARP MATERIAL UP AND ZIP-TIE IT TO THE REAR LID TO HELP COVER THE GAP.

NOTE: 2" (5cm) WIDE SPLICING TAPE IS SUPPLIED, AND CAN BE USED TO PROTECT THE TARP BY WRAPPING A SMALL LENGTH AROUND ANY SHARP POINTS ON THE SYSTEM.

25. INSTALL THE WIND DEFLECTOR OVER THE HYDRAULIC UNIT USING (6) STAINLESS STEEL BUTTON HEAD BOLTS, (3) AT 3" (7.6cm) AND (3) AT 2" (5cm). USE THE LARGE WIND DEFLECTOR BRACKET ON THE LEFT, AND THE SMALL WIND DEFLECTOR BRACKET ON THE RIGHT AS SHOWN BELOW (OPPOSITE IF THE INSTALL IS ON THE PASSENGER SIDE). USE THE LOC-TITE PROVIDED ON THE (1) MIDDLE BOLT SHOWN, AND LOCK NUTS ON THE (5) REMAINING BOLTS.

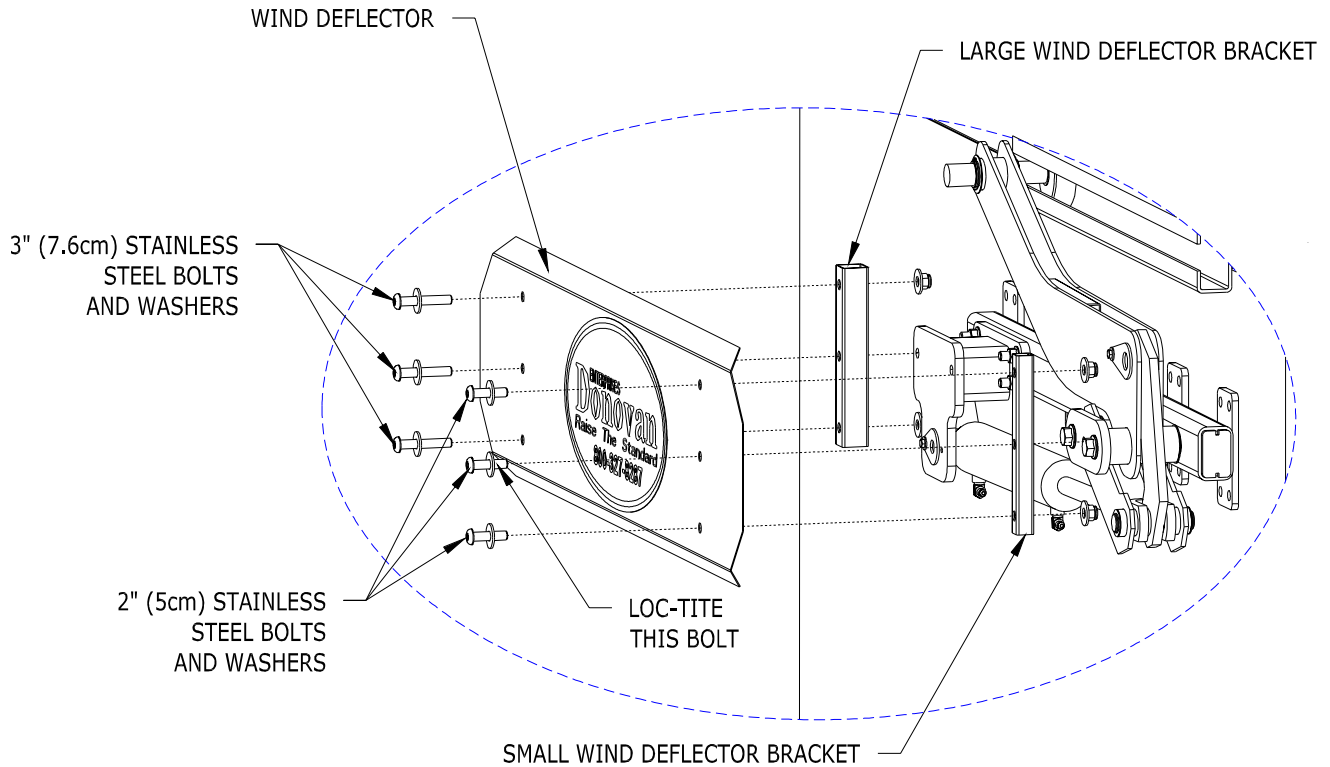

PERIODIC MAINTENANCE and INSPECTION:

-Daily:

1. Check mechanism for any damage or cracks.
2. Check tarpaulin for excessive wear and tear.
3. If equipped, check electrical cables for insulation damage.
4. Check hoses and fittings for cracks and leaks.
5. Check tarpaulin cable and adjust if loose.

- Weekly:

1. Check cylinders for leaks or excessive wear.
2. Check tightness of the fasteners.
3. Check hinges for excessive wear.
4. Check hydraulic actuator for any cracks, damage or excessive wear.
5. If equipped, check the hydraulic fluid level in hydraulic pump.

- Monthly:

1. Operate system to verify proper safe operation.
2. Check roller trolley and bearing for damage in front lid.

OPERATING INSTRUCTIONS

CAUTION: BEFORE OPERATING THIS OR ANY TARDER, CHECK YOUR SURROUNDINGS. LOOK FOR OVERHEAD POWER LINES, TREE LIMBS, ETC.. DO NOT OPERATE SYSTEM WHEN DANGER OF LIGHTNING STRIKE IS PRESENT.

CAUTION: When servicing or repairing the Sidewinder II system, disconnect power to the components from the vehicles battery.

NOTE: The noise level is less than 72dB(A)

TO OPEN TARP

PRESS UP ON SWITCH LEVER TO OPEN LID.

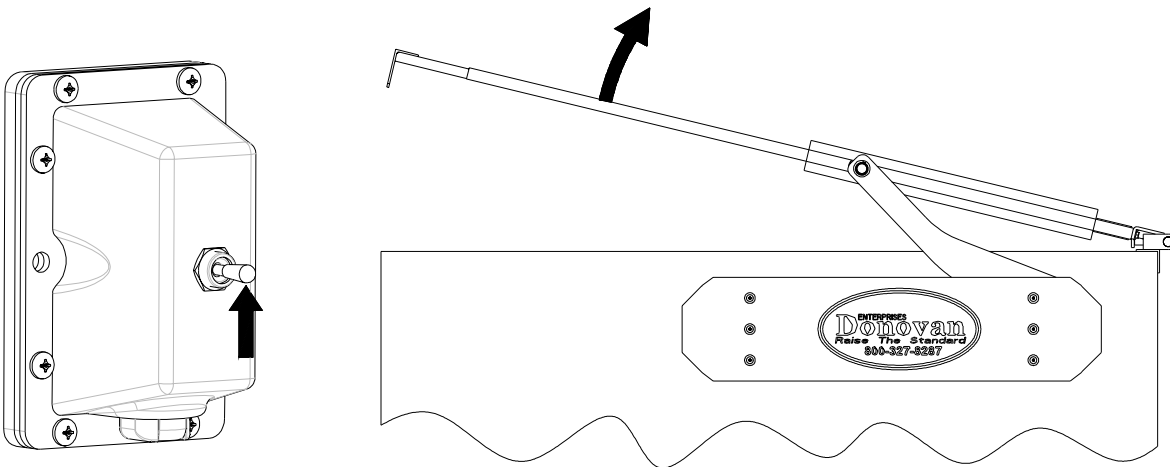

TO CLOSE TARP

PRESS DOWN ON SWITCH LEVER TO CLOSE LID.

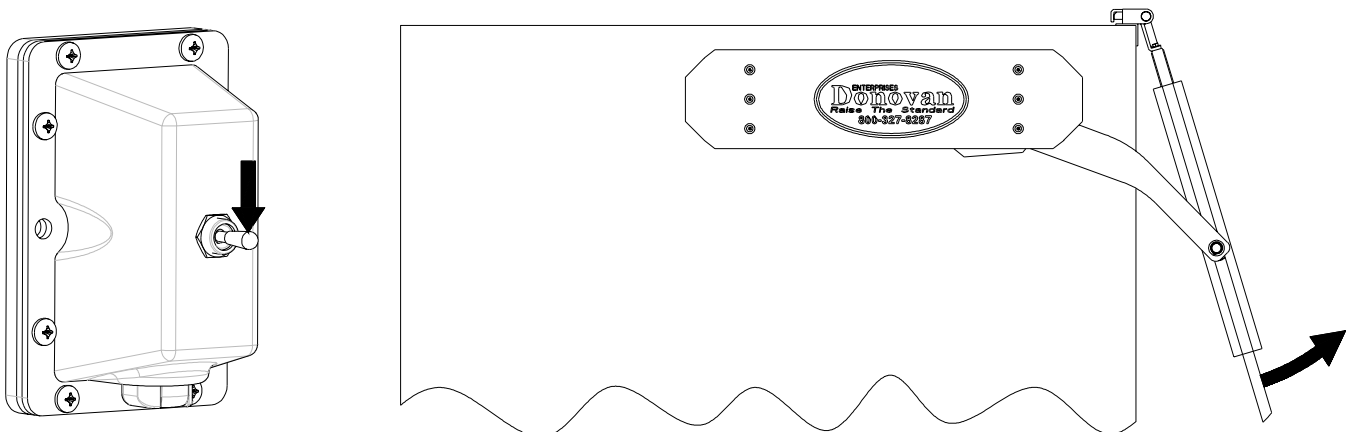

SAFETY STICKERS



CAUTION

BEFORE OPERATING TARPING MECHANISM, ENSURE ADEQUATE CLEARANCE ABOVE AND ALONGSIDE TRAILER. ACCOUNT FOR FULL WIDTH AND LENGTH OF TARP.

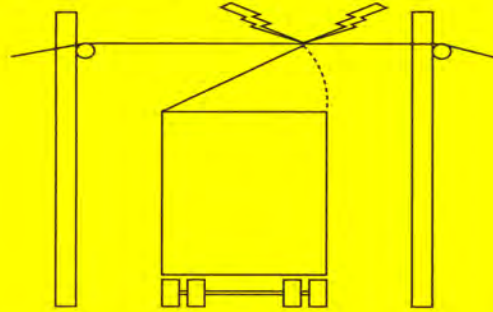

DO NOT USE A SOLID OR HEAVY TARP ON THE SIDEWINDER. THE SYSTEM WAS DESIGNED FOR USE WITH THE TARP SUPPLIED. THE USE OF ANY OTHER TARP MAY CAUSE SYSTEM FAILURE, INJURY, AND VOID THE WARRANTY. IF YOU NEED A REPLACEMENT TARP OR HAVE QUESTION ABOUT USING A DIFFERENT STYLE TARP, PLEASE CONTACT:
DONOVAN ENTERPRISES AT [1-866-498-6937](tel:1-866-498-6937) OR [1-800-327-8287](tel:1-800-327-8287)

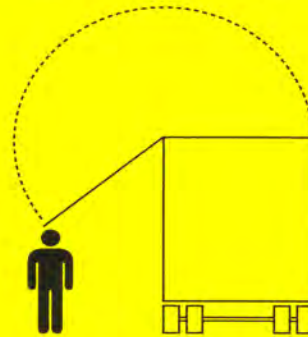

POSITION TARP FLUSH AGAINST SIDE OF TRAILER BEFORE LOADING. ENSURE TARP IS RESTING COMPLETELY ON TOP OF TRAILER PRIOR TO MOVING TRAILER.

CAUTION

BEFORE OPERATING TARP SYSTEM, ENSURE AREA ABOVE AND BESIDE VEHICLE IS CLEAR OF ELECTRICAL LINES OR OTHER OBSTRUCTIONS. ENSURE ADEQUATE LIGHTING WHENEVER OPERATING YOUR TARP COVERING SYSTEM.

CAUTION

TO PREVENT RISK OF INJURY, KEEP HANDS AWAY FROM MOVING PARTS WHILE TARP SYSTEM IS IN OPERATION.

CAUTION

DO NOT MOVE VEHICLE WITH TARP SYSTEM IN RAISED POSITION.

#4663

SIDEWINDER WET KIT

1. CONNECT "T" FITTING TO HYDRAULIC RETURN LINE.
2. CONNECT PRIORITY FLOW CONTROL VALVE TO HYDRAULIC SUPPLY LINE.
3. ATTACH HANDLE TO FRONT OF TRAILER IN A SUITABLE LOCATION FOR OPERATION.
4. HOOK UP 9' HYDRAULIC HOSE TO THE TRAILER'S CENTER-MOST HYDRAULIC CYLINDER FITTING.
5. HOOK UP 8' HYDRAULIC HOSE TO THE TRAILER'S OUTER-MOST HYDRAULIC CYLINDER FITTING.
6. WITH HYDRAULICS BEING SUPPLIED TO PRIORITY FLOW CONTROL VALVE, CYCLE HAND VALVE BACK AND FORTH 3 TO 4 TIMES TO PURGE ANY AIR FROM HYDRAULIC LINES.

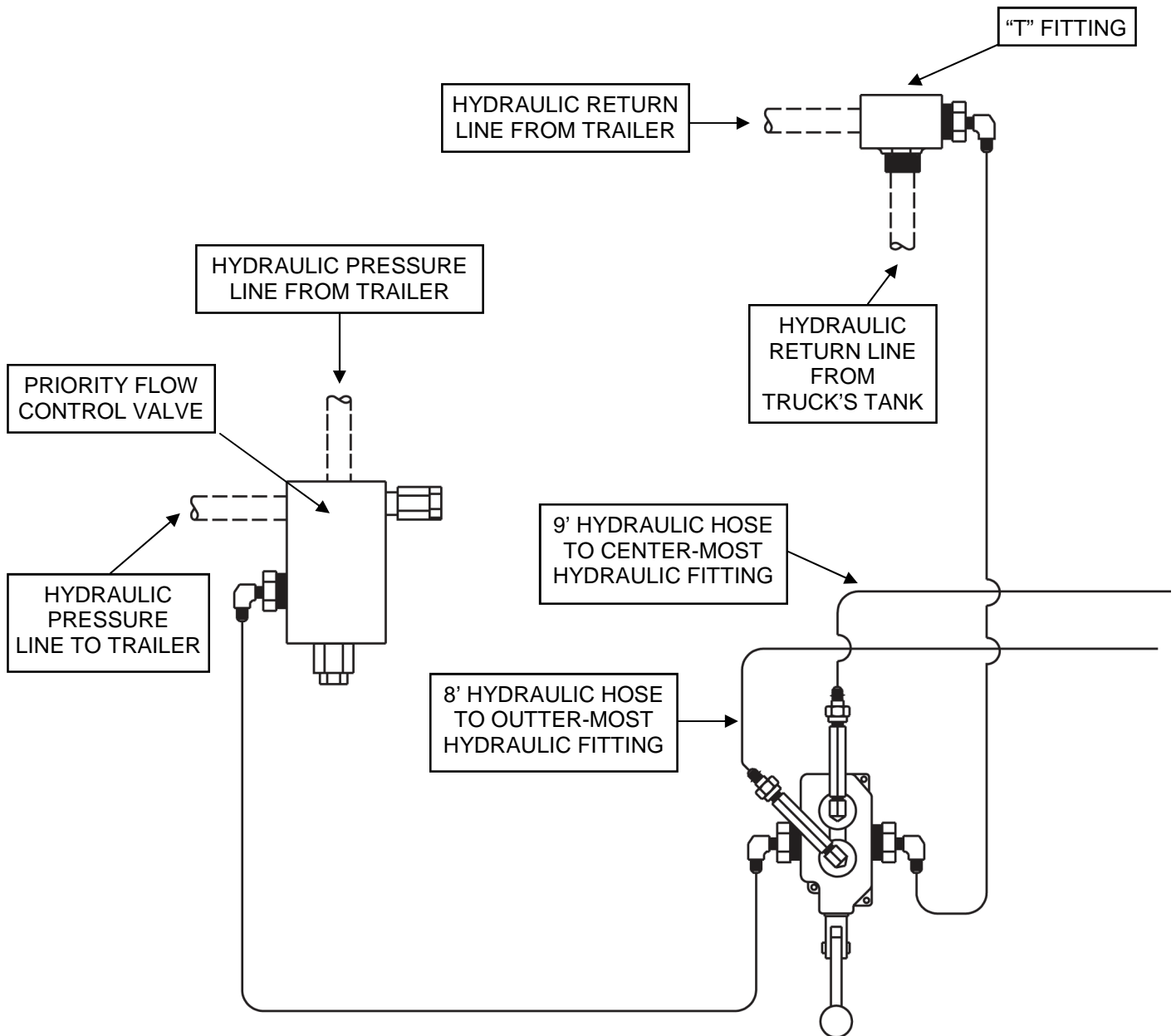

SIDEWINDER WET KIT PARTS BREAKDOWN

